

SNOWDOGG® 16153000 SCHEMATIC REFERENCE
XP PLOWS



Welcome

This manual is intended to aid in a better understanding of how the SnowDogg 16153000 expanding blade hydraulic power unit operates for use in troubleshooting.

The 16153000 power unit is used on all SnowDogg expanding plows and is fully backwards compatible.

Power unit operation relies on clean oil, properly functioning valves, and good electrical connections. Before doing extensive troubleshooting, check and clean all connections and make sure that the hydraulic fluid is clean and properly filled.

Cartridge valves are not intended to be serviced beyond cleaning and seal replacement. It is recommended to replace a valve that shows any signs of damage or distortion. Pressure spikes from plowing can cause the solenoid to stick without resulting in any visible damage. Spool valves, like those used in the 16153000, are susceptible to contamination so it is important to identify and eliminate the origin after cleaning and replacing valves.

It is often much faster to replace a valve than it is to do extensive troubleshooting.

LEGEND

Shown is the snowplow with NO valves energized – all cylinders are locked. This simplified representation shows the actual state of the valve poppets and spools to aid in understanding the circuit. Standard colors are used to represent the circuit in various states. Arrows have been added to depict the direction of oil flow and cylinder movement.

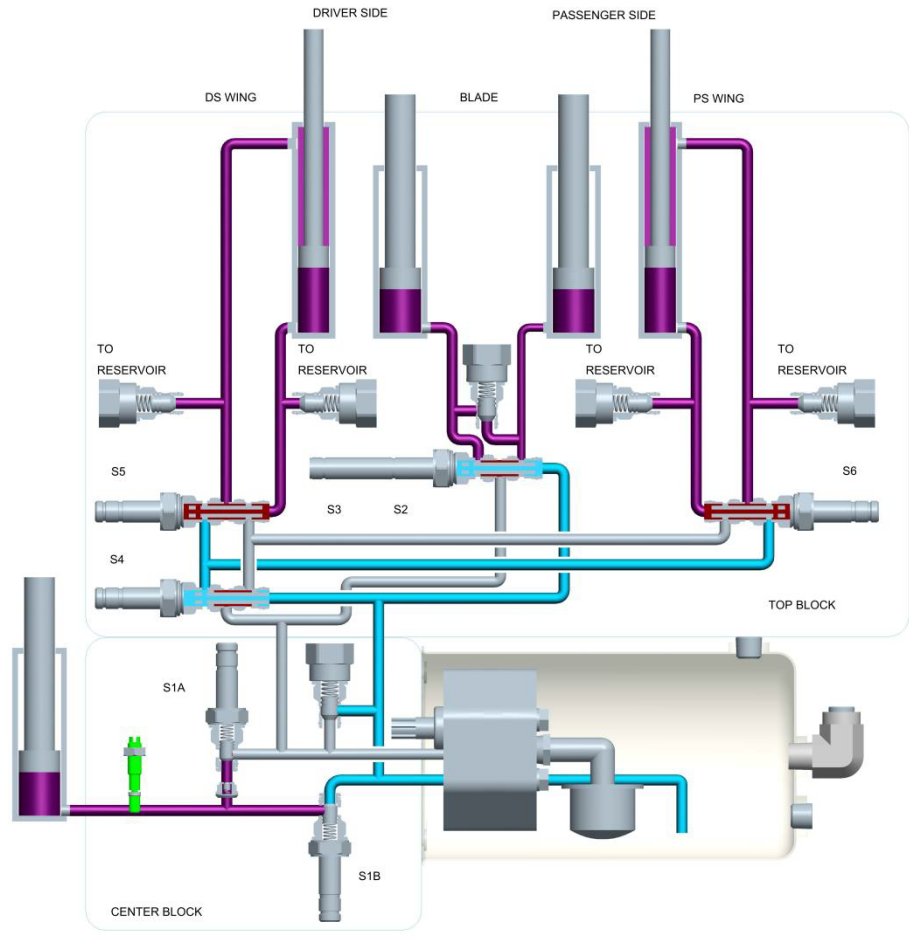
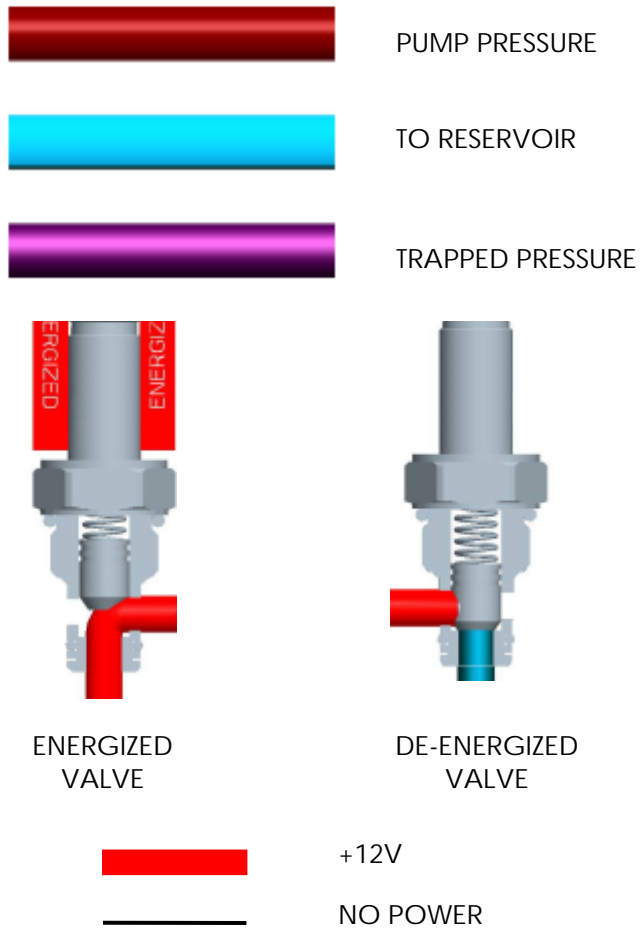

LIFT

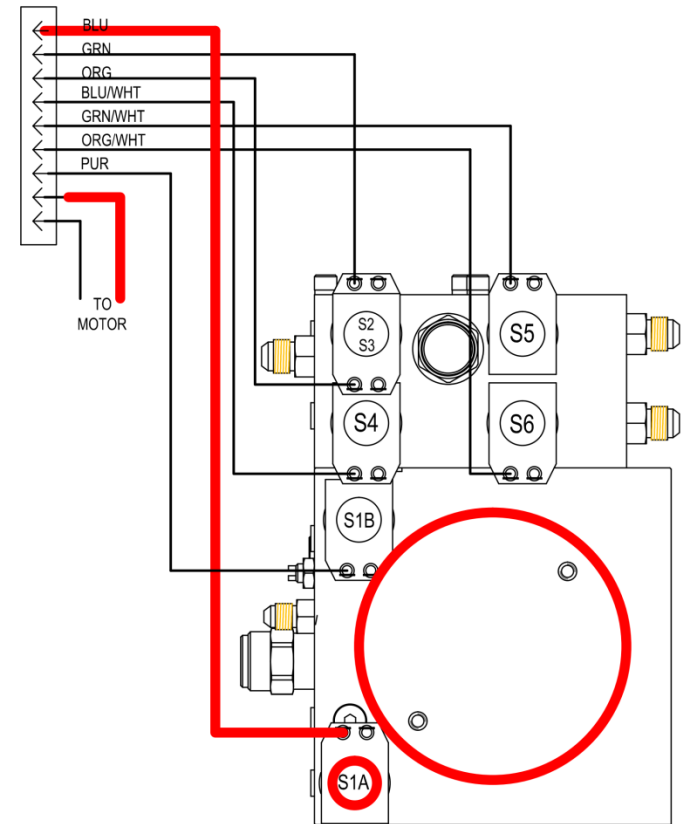
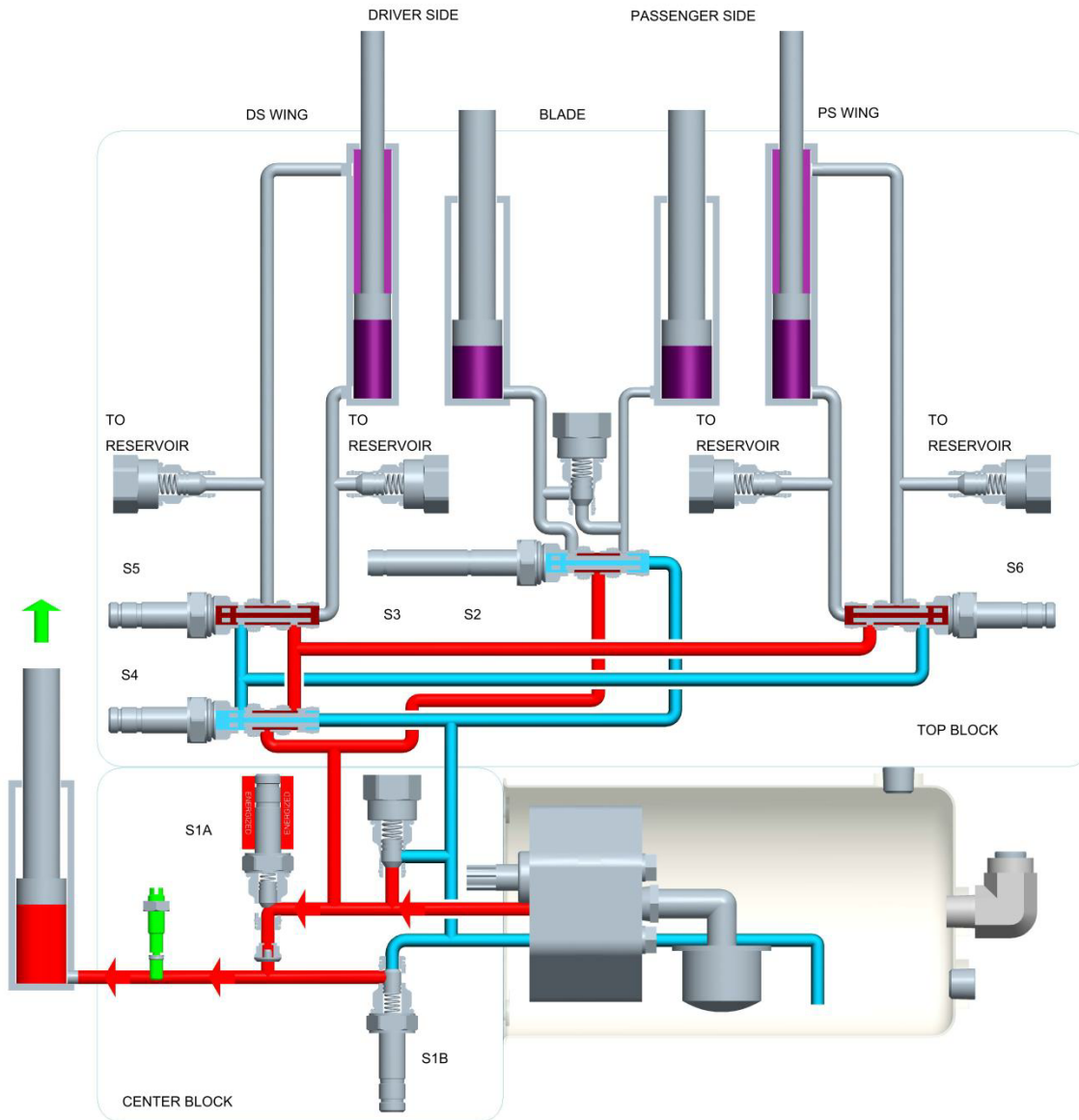

When the LIFT button is pressed, the MOTOR and coil S1A are energized. Fluid flows through VALVE S1A and a CHECK VALVE into the LIFT CYLINDER. VALVE S1B and the CHECK VALVE prevents the LIFT CYLINDER from retracting when the MOTOR turns off. If the cylinder reaches end of stroke while the LIFT button is still pressed, oil goes over the MAIN RELIEF to reservoir.

	LOGIC TABLE							
	MOTOR	A S1A	G S1B	B S2	C S3	D S4	E S5	F S6
LIFT	X	X	-	X	-	-	-	-
LOWER		-	X	-	-	-	-	-
FLOAT		-	X	-	-	-	-	-

LOWER/FLOAT

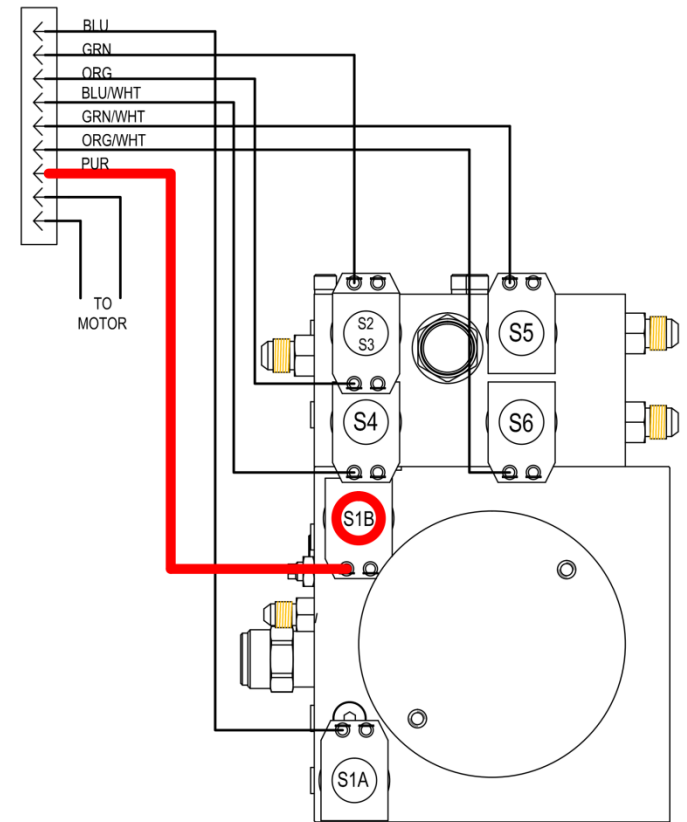
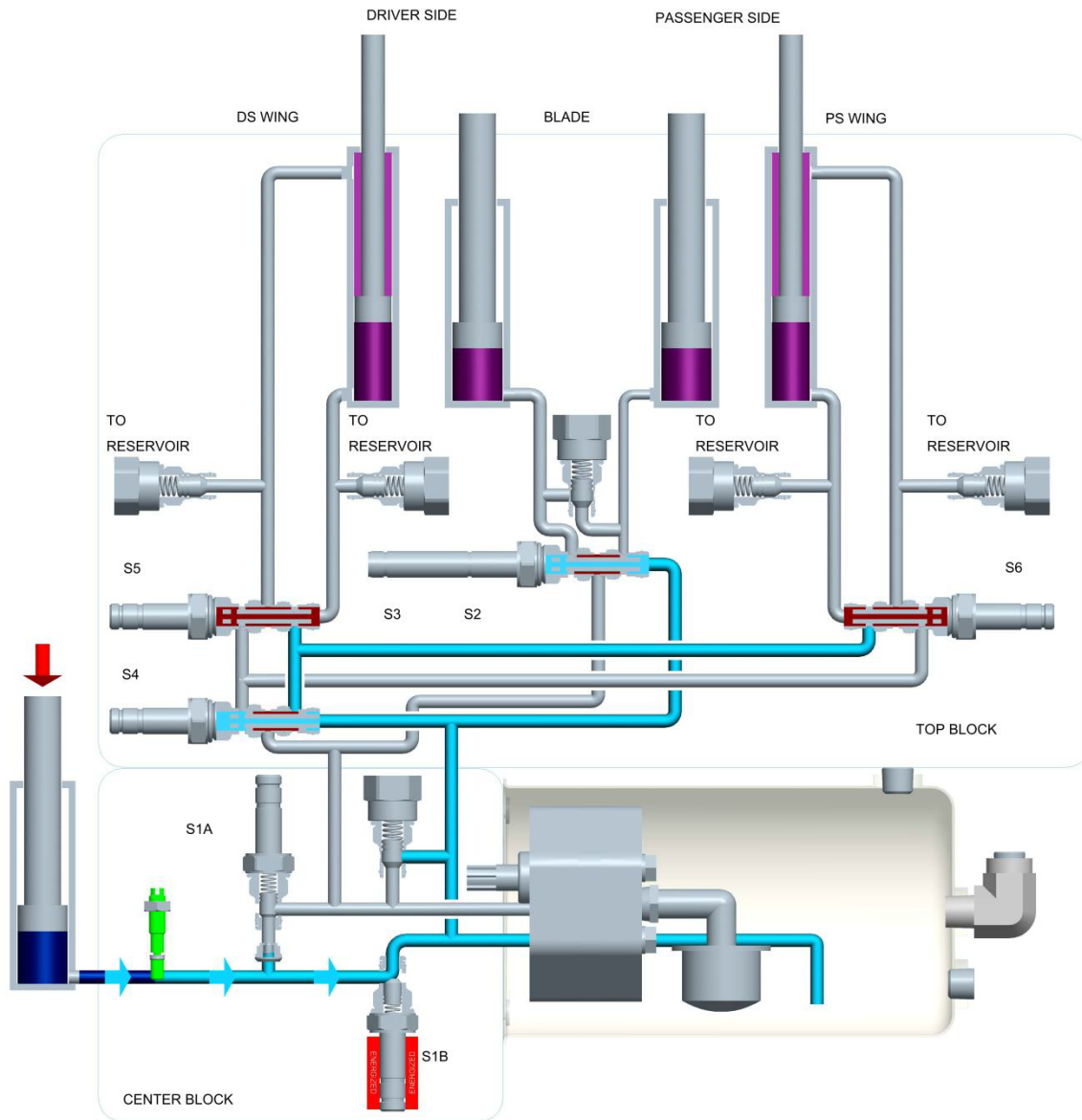

When the LOWER button is pressed, valve S1B is energized and fluid from the lift cylinder is drained to tank through valve S1B and the LOWERING NEEDLE to the reservoir. If the LOWER button is held for more than one second, the controller goes into FLOAT mode and lights the FLT indicator where valve S1B remains energized.

	LOGIC TABLE							
	MOTOR	A	G	B	C	D	E	F
		S1A	S1B	S2	S3	S4	S5	S6
LIFT	X	X	-	X	-	-	-	-
LOWER		-	X	-	-	-	-	-
FLOAT		-	X	-	-	-	-	-

LEFT WING EXTEND

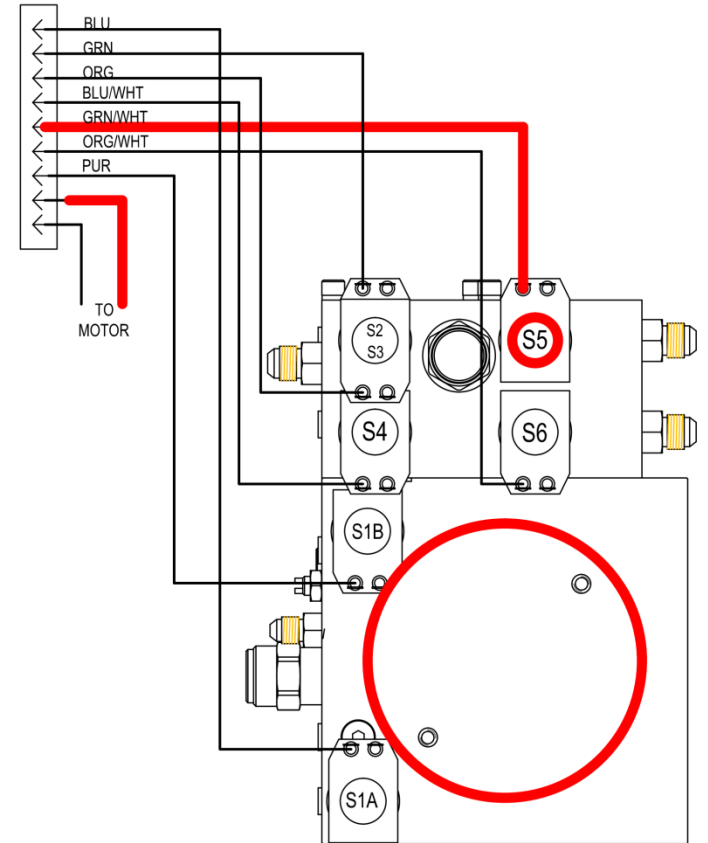
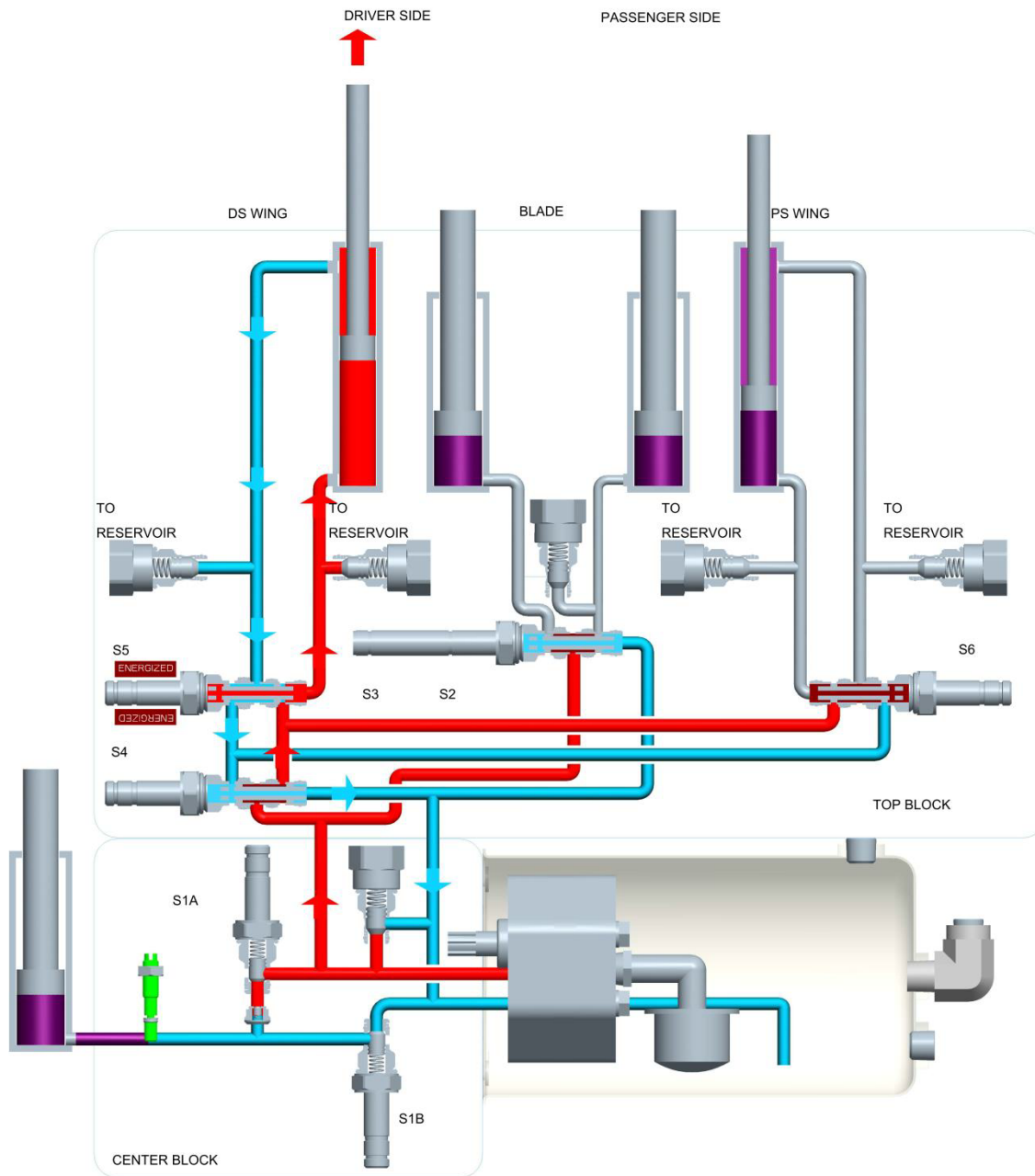

When the TOP LEFT button is pressed, valve S5 is energized. Fluid flows through valves S4, S5 into the bore end of the DS WING CYLINDER. Fluid exits the rod end of the DS WING CYLINDER and goes through valve S5 and S4 to the reservoir. The WING CYLINDER is protected by port reliefs that drain to reservoir. The cylinder is held in place by valve S5 being closed when de-energized.

	LOGIC TABLE							
	MOTOR	A S1A	G S1B	B S2	C S3	D S4	E S5	F S6
LEFT OUT	X	-	-	-	-	-	X	-
LEFT IN	X	-	-	-	-	X	X	-
ANG LEFT	X	-	-	X	-	-	-	-

LEFT WING RETRACT

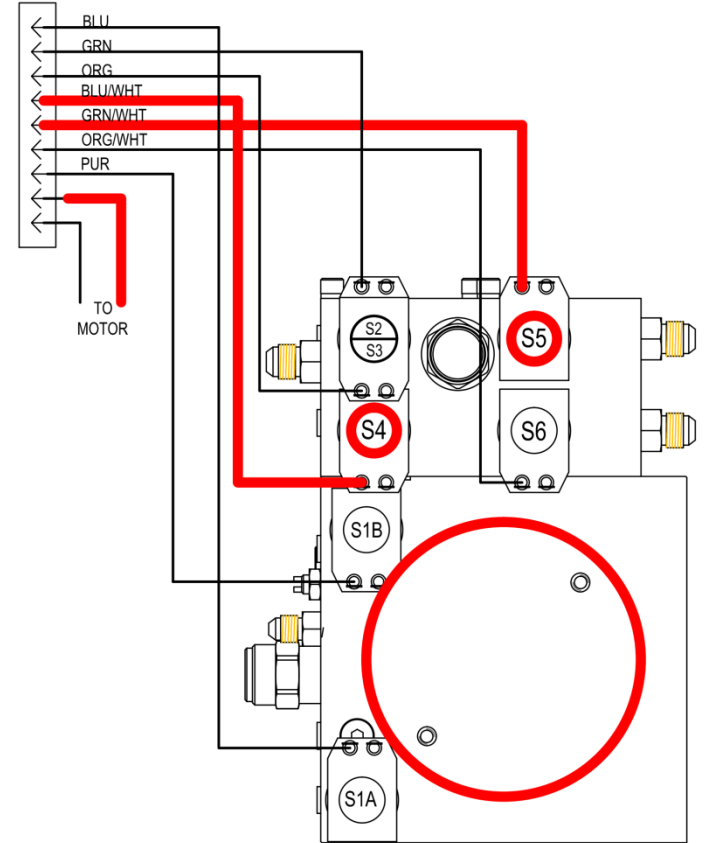
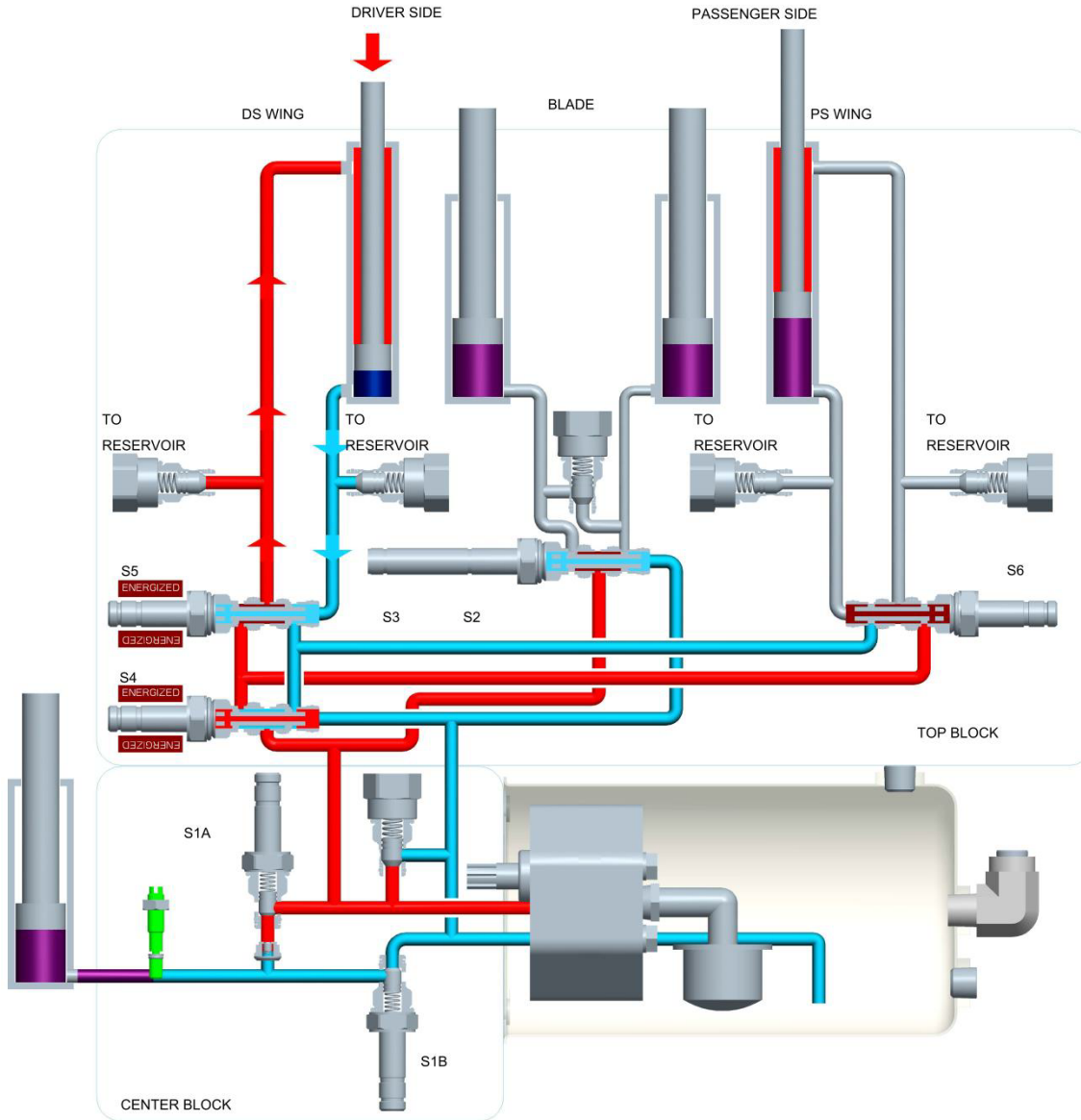

When the BOTTOM LEFT button is pressed, coils S4 and S5 are energized. Fluid flows through valves S4, S5 into the rod end of the DS WING CYLINDER. Fluid exits the bore end of the DS WING CYLINDER and goes through valve S5 and S4 to the reservoir. The WING CYLINDER is protected by port reliefs that drain to reservoir. The cylinder is held in place by valve S5 being closed when de-energized.

	LOGIC TABLE							
	MOTOR	A S1A	G S1B	B S2	C S3	D S4	E S5	F S6
LEFT OUT	X	-	-	-	-	-	X	-
LEFT IN	X	-	-	-	-	X	X	-
ANG LEFT	X	-	-	X	-	-	-	-

ANGLE LEFT

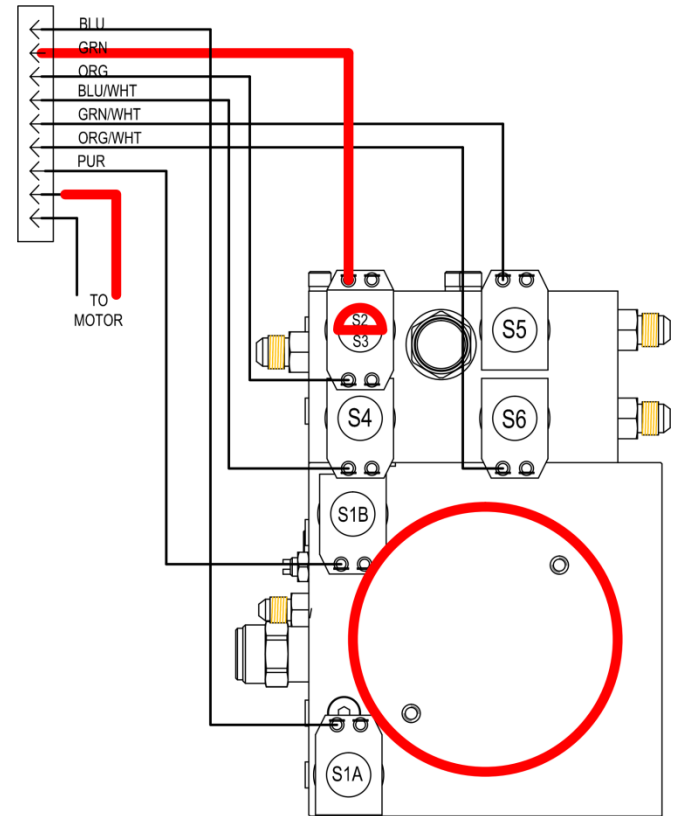
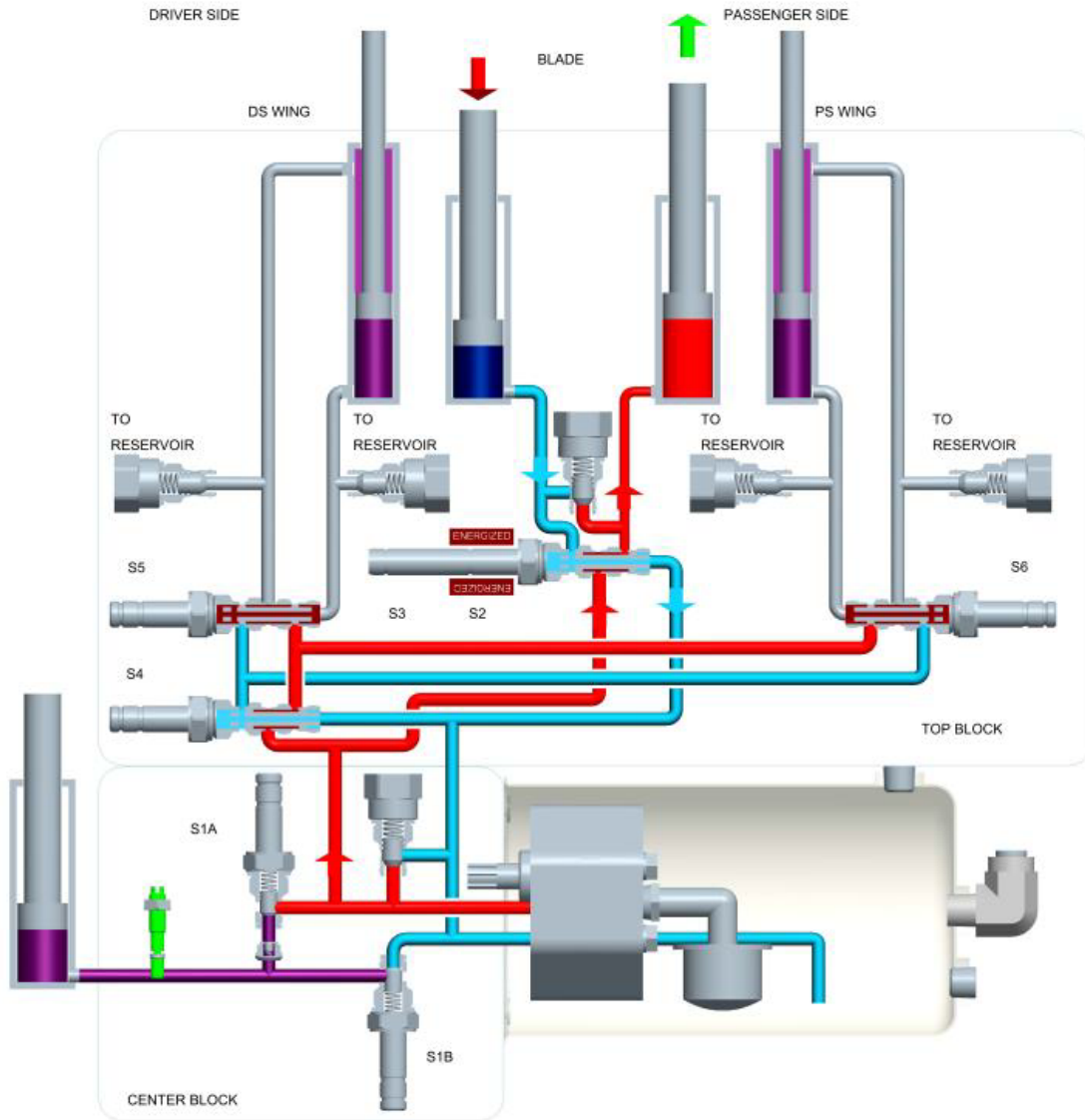

When the MIDDLE LEFT button is pressed, coil S2 is energized. Fluid flows through valve S2/S3 to the bore end of the RIGHT cylinder. Fluid exits the bore end of the LEFT cylinder and flows through valve S2/S3 to the reservoir. The ANGLE CYLINDERS are protected by a crossover relief that drains to other side. The cylinder is held in place by valve S2/S3 being closed when de-energized.

	LOGIC TABLE							
	MOTOR	A S1A	G S1B	B S2	C S3	D S4	E S5	F S6
LEFT OUT	X	-	-	-	-	-	X	-
LEFT IN	X	-	-	-	-	X	X	-
ANG LEFT	X	-	-	X	-	-	-	-

RIGHT WING EXTEND

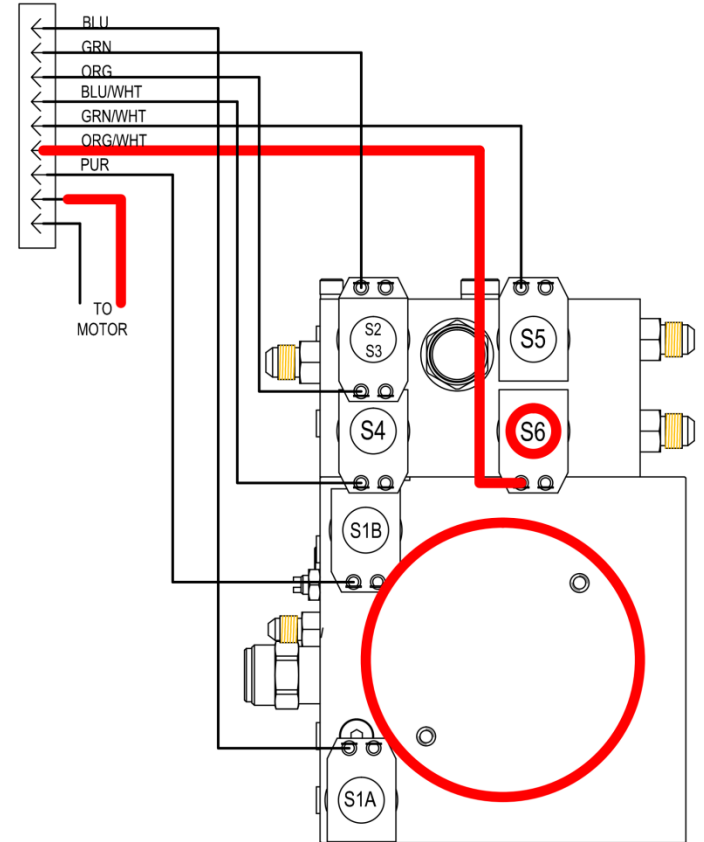
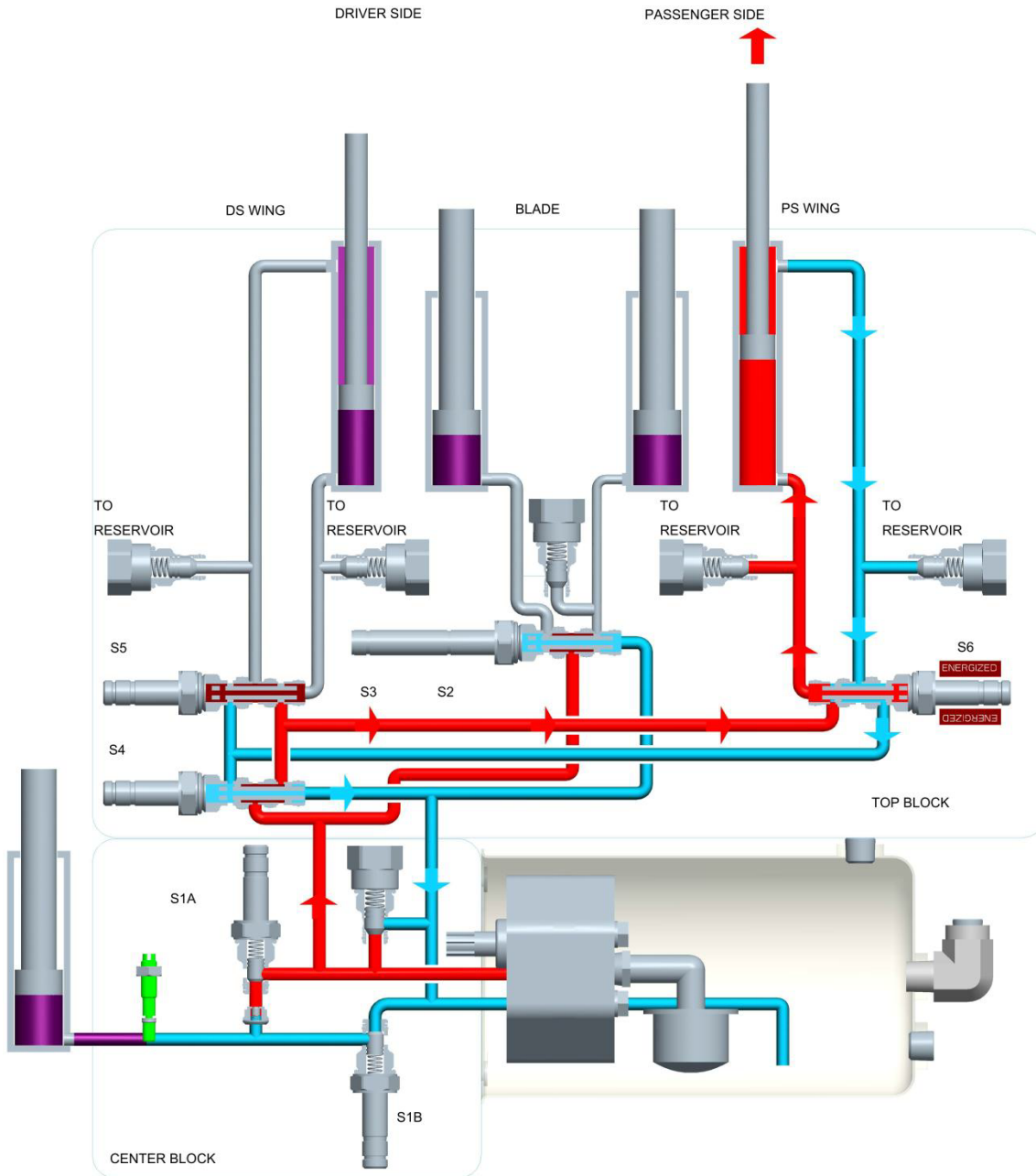

When the TOP LEFT button is pressed, valve S6 is energized. Fluid flows through valves S4, S6 into the bore end of the PS WING CYLINDER. Fluid exits the rod end of the PS WING CYLINDER and goes through valve S6 and S4 to the reservoir. The WING CYLINDER is protected by port reliefs that drain to reservoir. The cylinder is held in place by valve S6 being closed when de-energized.

	LOGIC TABLE							
	MOTOR	A S1A	G S1B	B S2	C S3	D S4	E S5	F S6
RIGHT OUT	X	-	-	-	-	-	-	X
RIGHT IN	X	-	-	-	-	X	-	X
ANG RIGHT	X	-	-	-	X	-	-	-

RIGHT WING RETRACT

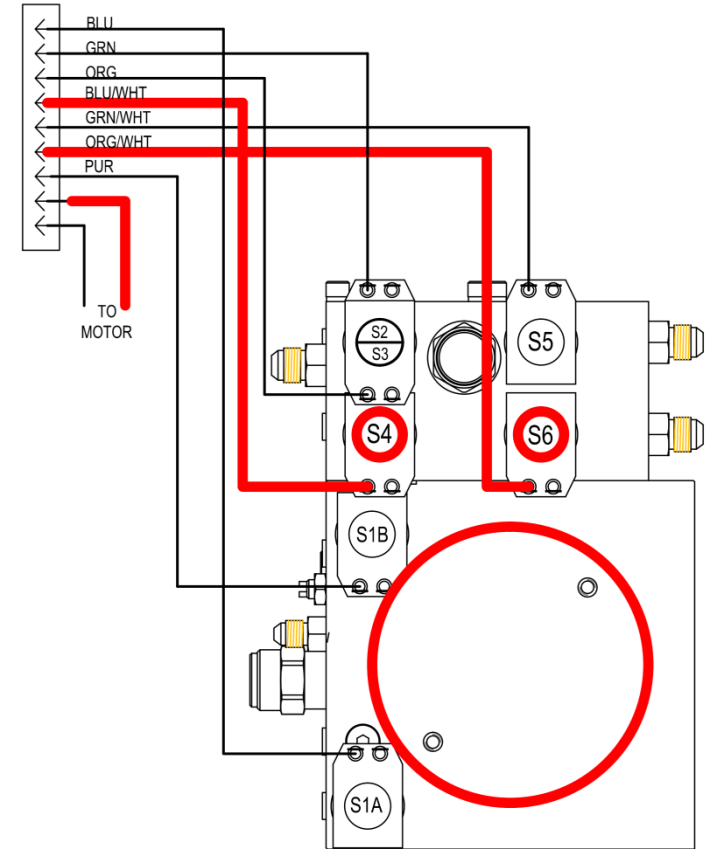
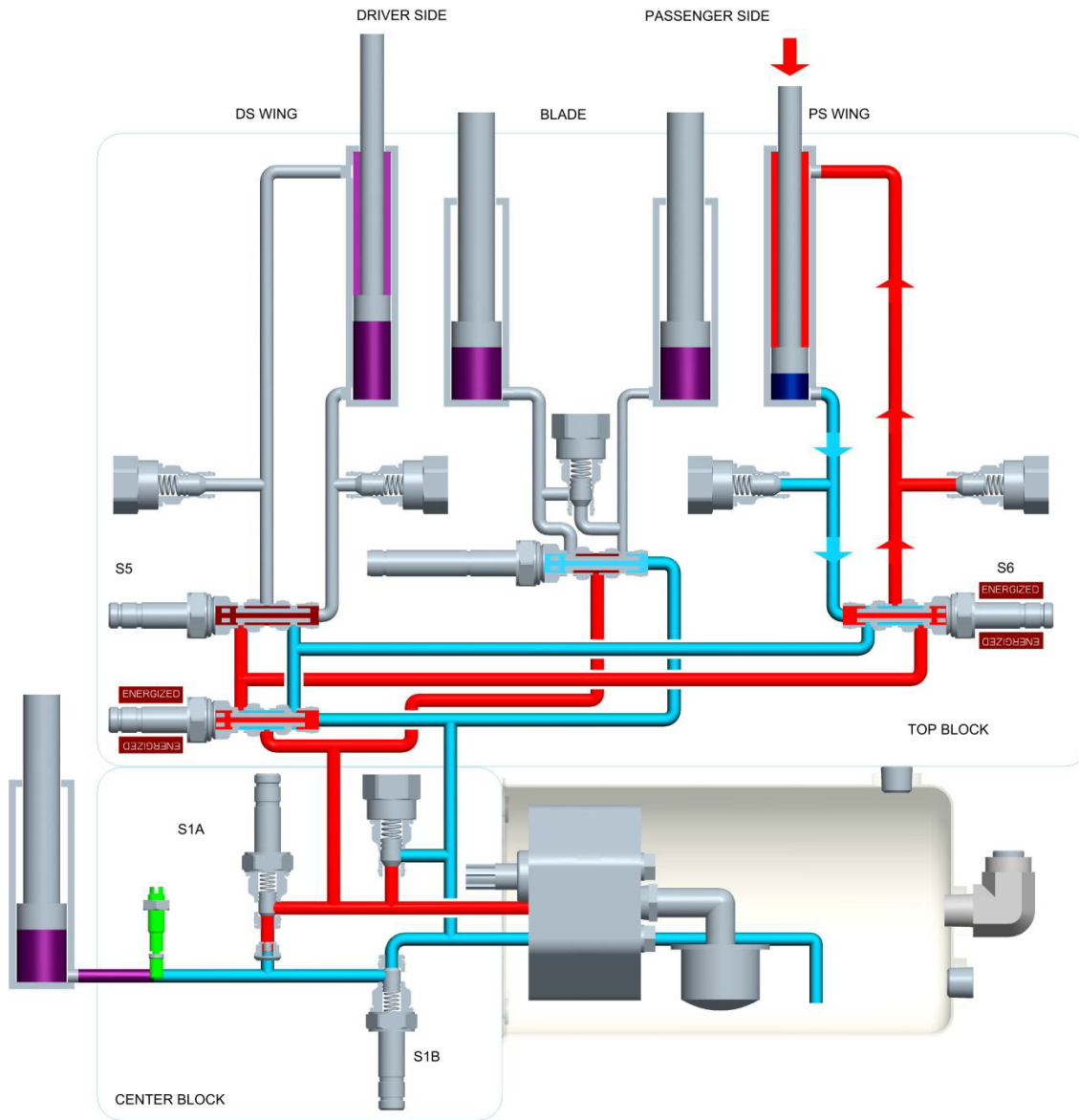

When the BOTTOM LEFT button is pressed, coils S4 and S6 are energized. Fluid flows through valves S4, S6 into the rod end of the DS WING CYLINDER. Fluid exits the bore end of the DS WING CYLINDER and goes through valve S6 and S4 to the reservoir. The WING CYLINDER is protected by port reliefs that drain to reservoir. The cylinder is held in place by valve S6 being closed when de-energized.

	LOGIC TABLE							
	MOTOR	A S1A	G S1B	B S2	C S3	D S4	E S5	F S6
RIGHT OUT	X	-	-	-	-	-	-	X
RIGHT IN	X	-	-	-	-	X	-	X
ANG RIGHT	X	-	-	-	X	-	-	-

ANGLE RIGHT

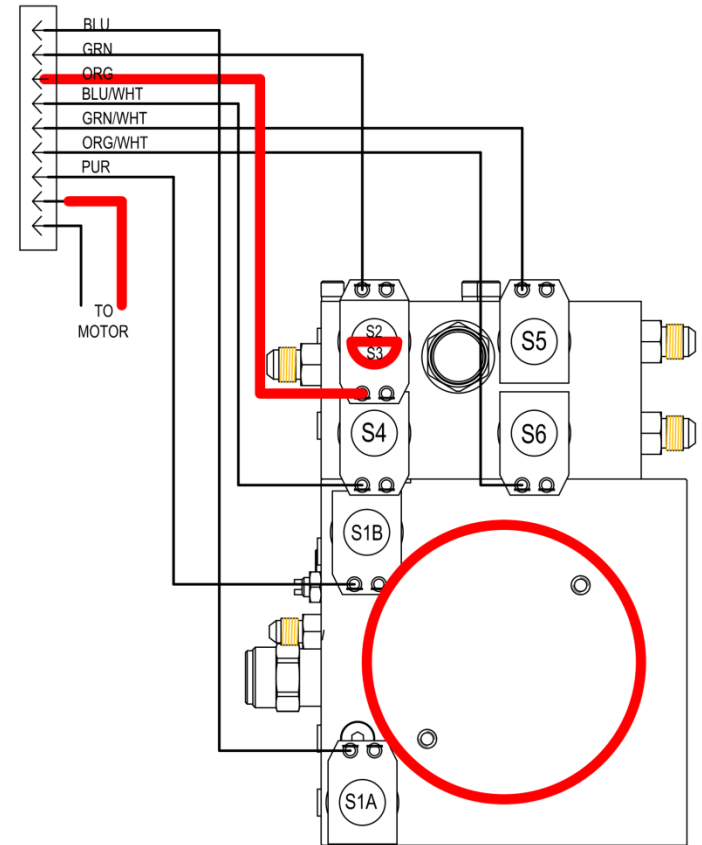
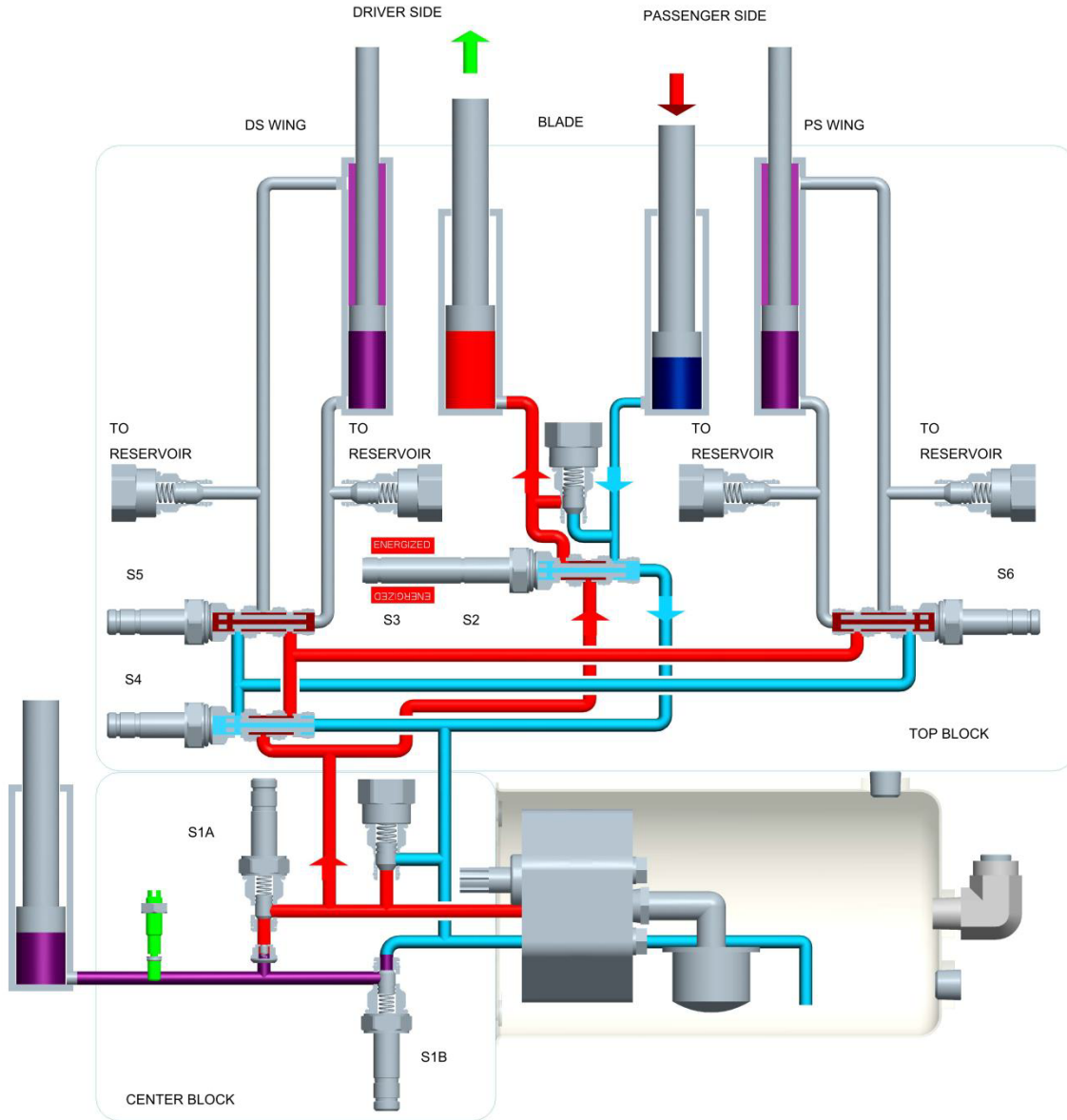

When the MIDDLE RIGHT button is pressed, coil S3 is energized. Fluid flows through valve S2/S3 to the bore end of the LEFT cylinder. Fluid exits the bore end of the RIGHT cylinder and flows through valve S2/S3 to the reservoir. The ANGLE CYLINDERS are protected by a crossover relief that drains to other side. The cylinder is held in place by valve S2/S3 being closed when de-energized.

	LOGIC TABLE							
	MOTOR	A S1A	G S1B	B S2	C S3	D S4	E S5	F S6
RIGHT OUT	X	-	-	-	-	-	-	X
RIGHT IN	X	-	-	-	-	X	-	X
ANG RIGHT	X	-	-	-	X	-	-	-

RAPIDLINK MOUNT MODE

The Rapidlink mounting system uses a switch on the plow liftframe to raise and lower the plow remotely. Activating MOUNT MODE on the controller energizes pin D on the XP plow grill connector. This is the BLUE and WHITE wire that goes to S4. This is only intended to provide power to the switch and will not move the plow.

Mount mode allows you to adjust the position of the lift frame ears when necessary to allow for mounting to a truck.

The switch will provide power to the S1A LIFT VALVE or the S1B DROP VALVE to raise or lower the plow. When the controller detects voltage on the BLUE wire for S1A it energizes the motor.

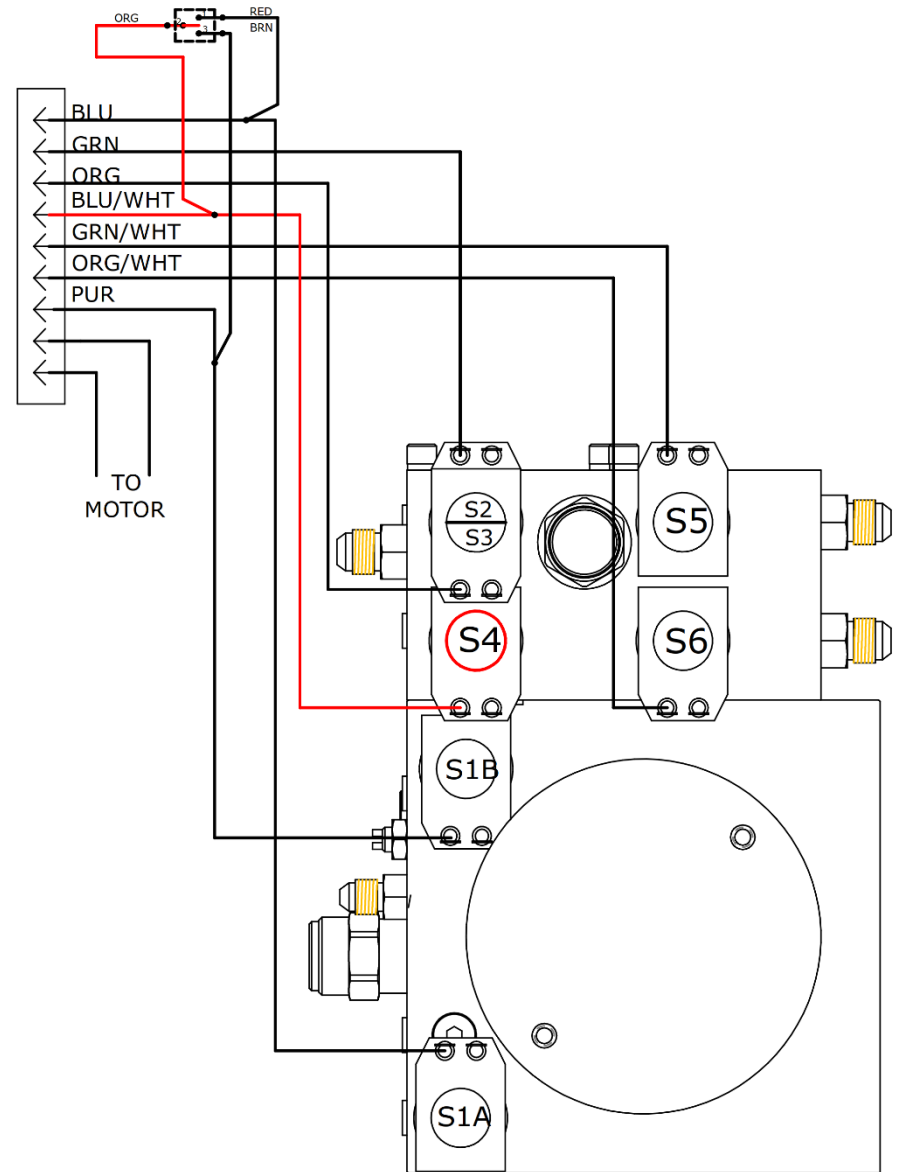

SWITCH	LOGIC TABLE							
	MOTOR	A S1A	G S1B	B S2	C S3	D S4	E S5	F S6
MIDDLE	-	-	-	-	-	-	-	-
UP (LIFT)	-	-	-	-	-	-	-	-
DOWN (DROP)	-	-	-	-	-	-	-	-

RAPIDLINK MOUNT MODE – LIFT AND DROP

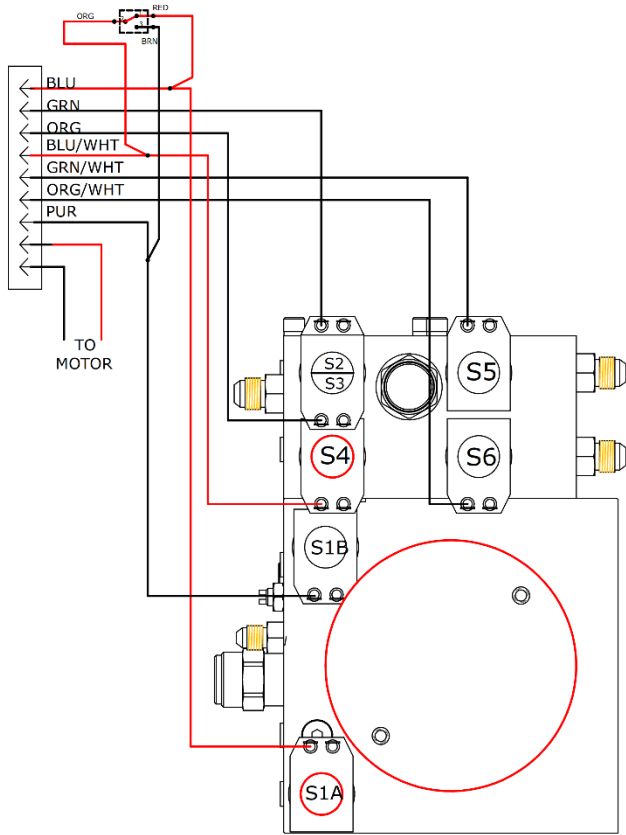

When the plow is put in in mount mode and the jack switch is in UP position, the controller will detect voltage at pin A and energize the motor briefly, tilting the lift frame forward as the lift cylinder extends.

SWITCH	LOGIC TABLE							
	MOTOR	A S1A	G S1B	B S2	C S3	D S4	E S5	F S6
MIDDLE	-	-	-	-	-		-	-
UP (LIFT)		-	-	-	-		-	-
DOWN (DROP)	-	-		-	-		-	-

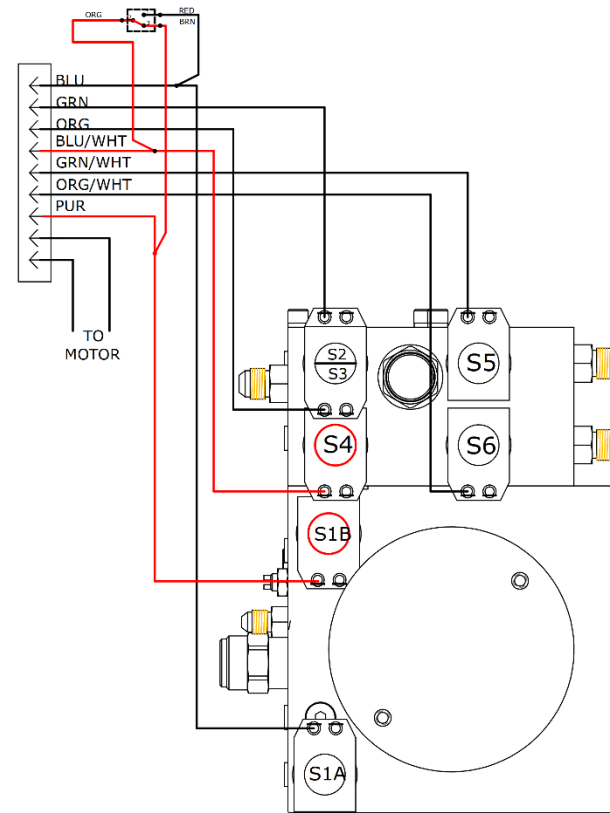

When the plow is put in in mount mode and the jack switch is in DOWN position, valve S1B will be energized briefly, allowing the lift frame to tilt back as the lift cylinder compresses.

SWITCH	LOGIC TABLE							
	MOTOR	A S1A	G S1B	B S2	C S3	D S4	E S5	F S6
MIDDLE	-	-	-	-	-		-	-
UP (LIFT)		-	-	-	-		-	-
DOWN (DROP)	-	-		-	-		-	-

NOTES